

SLP Series N/C

Solenoid Valves Normally Closed



Features

- Available in 230VAC, 110VAC, 12VDC, 24VDC, 24VAC
- Thread standard: ISO 228/1
- Coil Rating: IP 65
- Coil Duty Cycle: 100%
- EPDM model is WRAS approved
- Available sizes -
1/8", 1/4", 3/8", 1/2", 3/4", 1", 1.1/4", 1.1/2", 2"
- Flanged version available in
1", 1.1/4", 1.1/2", 2", 2.1/2", 3", 4"

N.	Part Name	Materials
1	Body	Brass
2	Diaphragm	NBR / EPDM / Viton
3	Diaphragm Spring	Stainless Steel 304
4	Valve Cover	Brass
5	Bolt	Stainless Steel 302
6	Pilot Seal	NBR / EPDM / Viton
7	Pilot	Stainless Steel 1J117
8	Pilot Spring	Stainless Steel 304
9	O-Ring	NBR / EPDM / Viton
10	Plunger Tube Unit	Stainless Steel 304 + 1J117
11	Coil	Enamelled Wire
12	Plug	Nylon
13	Washer	Stainless Steel 302
14	Lock Nut	Stainless Steel 302

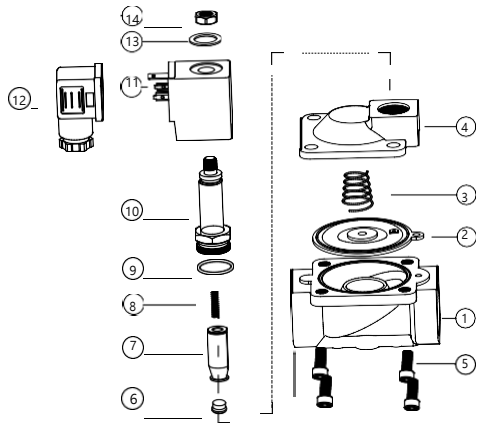

Main Dimensions

Orifice: 3mm & 4mm
Port: 1/8", 1/4" & 3/8"

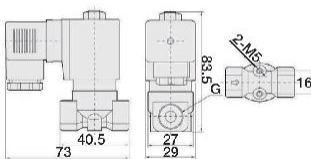

Orifice: 10.5mm
Port: 1/4", 3/8" & 1/2"

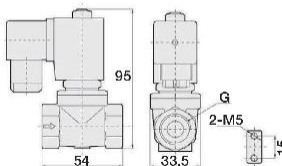

Large Orifice
See table opposite

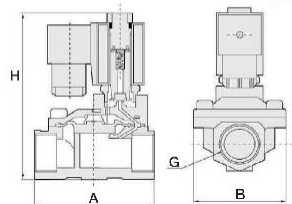

SLP Series N/C

Valve Specification

Port Size (G)	Orifice	Kv Value	Pressure Difference (Bar)				Max. Temp (°C)	VA AC 230V	VA AC 110V	VA AC 24V	W DC 24V	Diaphragm	Main Dimension AxBxH
			Min.	Air / Gas	Water / Hot Liquid	max. working Pressure							
1/8"	3	0.20	0	13	13	10	80	22	22	18	13	NBR	-
	3	0.20	0	13	13	-	120	22	22	18	13	EPDM	-
	3	0.20	0	13	13	10	120	22	22	18	13	VITON	-
1/4"	3	0.20	0	13	13	10	80	22	22	18	13	NBR	-
	3	0.20	0	13	13	-	120	22	22	18	13	EPDM	-
	3	0.20	0	13	13	10	120	22	22	18	13	VITON	-
	10.5	1.27	0	16	16	13	80	22	22	18	13	NBR	-
	10.5	1.27	0	16	16	-	120	22	22	18	13	EPDM	-
	10.5	1.27	0	16	16	13	120	22	22	18	13	VITON	-
3/8"	3	0.26	0	13	13	10	80	22	22	18	13	NBR	-
	3	0.26	0	13	13	10	120	22	22	18	13	EPDM	-
	3	0.26	0	13	13	10	120	22	22	18	13	VITON	-
	4	0.52	0	8	8	6	80	22	22	18	13	NBR	-
	4	0.52	0	8	8	6	120	22	22	18	13	EPDM	-
	4	0.52	0	8	8	6	120	22	22	18	13	VITON	-
	10.5	1.45	0	16	16	13	80	22	22	18	13	NBR	-
	10.5	1.45	0	16	16	-	120	22	22	18	13	EPDM	-
	10.5	1.45	0	16	16	13	120	22	22	18	13	VITON	-
	13	3.89	0.5	16	16	13	80	22	22	18	13	NBR	66x48x112
	13	3.89	0.5	16	16	-	120	22	22	18	13	EPDM	66x48x112
13	3.89	0.5	16	16	13	120	22	22	18	13	VITON	66x48x112	
1/2"	10.5	1.51	0	16	16	13	80	22	22	18	13	NBR	-
	10.5	1.51	0	16	16	-	120	22	22	18	13	EPDM	-
	10.5	1.51	0	16	16	13	120	22	22	18	13	VITON	-
	13	3.89	0.5	16	16	13	80	22	22	18	13	NBR	66x48x112
	13	3.89	0.5	16	16	-	120	22	22	18	13	EPDM	66x48x112
	13	3.89	0.5	16	16	13	120	22	22	18	-	VITON	66x48x112
3/4"	20	6.57	0.5	16	16	13	80	22	22	18	13	NBR	75x58x118
	20	6.57	0.5	16	16	-	120	22	22	18	13	EPDM	75x58x118
	20	6.57	0.5	16	16	13	120	22	22	18	13	VITON	75x58x118
1"	25	10.37	0.5	16	16	13	80	22	22	18	13	NBR	96x70x131
	25	10.37	0.5	16	16	-	120	22	22	18	13	EPDM	96x70x131
	25	10.37	0.5	16	16	13	120	22	22	18	13	VITON	96x70x131
1¼"	35	19.01	0.5	16	16	13	80	22	22	18	13	NBR	131x96x146
	35	19.01	0.5	16	16	-	120	22	22	18	13	EPDM	131x96x146
	35	19.01	0.5	16	16	13	120	22	22	18	13	VITON	131x96x146
1½"	40	25.92	0.5	16	16	13	80	22	22	18	13	NBR	131x96x146
	40	25.92	0.5	16	16	-	120	22	22	18	13	EPDM	131x96x146
	40	25.92	0.5	16	16	13	120	22	22	18	13	VITON	131x96x146
2"	50	41.47	0.5	16	16	13	80	22	22	18	13	NBR	165x120x167
	50	41.47	0.5	16	16	-	120	22	22	18	13	EPDM	165x120x167
	50	41.47	0.5	16	16	13	120	22	22	18	13	VITON	165x120x167

SLP Series N/C