

## Specification

### Pipe Threads

The machined threads of Crane fittings are supplied to conform with the gauging requirements of BS EN 10226-2. Threads on all fittings are chamfered to assist assembly and avoid 'cross threading'. Female fittings have a chamber behind the thread, permitting the male thread to be assembled without restriction or 'bottoming'.

### Design Standards

ISO 49 is the international standard for 'Malleable cast iron fittings' threaded to ISO 7-1.

BS EN 10242 is the British European Standard for 'Threaded pipe fittings in malleable cast iron' first published in August 1995 and very closely follows ISO 49.

All European Standards have to be adopted by the member countries of the EU and any conflicting national standards withdrawn. BS 143 and 1256 has been retained to cover those fittings not in BS EN 10242. It should also be noted that BS EN 10242 details a number of fitting types and sizes which were not included in BS 143 & 1256 because they were not in regular demand and/or not available from UK manufacturers. BS 143 & 1256 specifies requirements for the design and performance of 'Malleable cast iron and cast copper alloy threaded pipe fittings' and has developed over many years.

BS 143 & 1256 were amended in August 1995 to delete those fittings now covered by BS EN 10242, so the scope of BS 143 & 1256 is now essentially:

- (a) BS 143 design and BS 1256 design fittings in malleable iron not covered by BS EN 10242,
- (b) BS 143 design fittings threaded to ANSI B1.20.1 (NPT)

### Conformance of Crane Fittings

Both malleable iron and steel fittings have been verified by the British Standards Institute (BSI) as conforming to BS EN 10242 and BS 143 & 1256, as appropriate, and as such are permitted to bear the British Standards Kitemark Logo - Kitemark Licence No. KM00382.

Some small size fittings are manufactured in steel and will conform to BS EN 10241.

### UL Certified Products

Many malleable fittings are covered by UL certification. UL is a global leader in testing, inspection, certification, auditing and validation. UL Listing means that UL has tested representative samples of the product and determined that it meets UL's requirements. These requirements are based primarily on UL's published and nationally recognised Standards for Safety. UL approved fittings have been approved for use in fire protection such as sprinkler systems. Malleable Fittings Covered: 140, 144, 145, 146, 147, 148, 149, 150, 151, 152, 155, 156, 161, 171, 177, 179, 185, 192, 193, 197, 199.

Constructed of blackheart malleable iron according to Standard BS EN 1562, Grade EN-GJMB-300-6 Fittings may also utilise an optional zinc coating (galvanised) as described in BS EN 10242.

For the details of the fittings range covered see the UL Certifications Directory at: [www.ul.com/database](http://www.ul.com/database).

### The Pressure Equipment Directive 2014/68/EU (PED)

The Directive applies to the design, manufacture and conformity of pressure equipment and assemblies of pressure equipment with a maximum allowable pressure greater than 0.5 bar. Individual piping components, such as fittings, are excluded from the scope of the Directive and therefore cannot be CE marked. However, Crane pipe fittings are manufactured to the appropriate European standards and satisfy the essential safety requirements of the PED.

## Key Features

- **Taper to taper thread joints ensure full engagement, eliminating localised stress on pipe or fitting, and offering a substantial pressure seal**
- **Design standard BS EN 10242**
- **Thread standard BS EN 10226-2 taper**
- **UL approved for use on sprinkler systems**
- **Kitemark approved by BSI**

## Specification

### Piping Installation

The below information is compiled from British and International standards on Pipe Threads BS EN 10226 (supercedes BS 21) and Pipe Fittings standards BS EN 10242, BS 143 & 1256 and ISO 49.

Much unnecessary labour and creation of random lengths of pipe might be saved by the application of a few simple figures by the engineer when erecting the pipe line. Generally the pipeline, section by section, is either accommodated within fixed limits, usually the lines of building construction, or is fixed by prescribed dimensions. Except in the case of a continuous run of piping connected either by sockets or flanges, the engineer needs to know the length of pipe required to make up between fixed positions of fittings prior to cutting and threading.

The diagram below and table of 'A' dimensions indicates the length of thread engagement of BS EN 10226 taper pipe threads in nominal sizes 1/8 to 6 inch.

The approximate pipe length is calculated by using the expression  $L = C - (B1 + B2) + 2A$ .

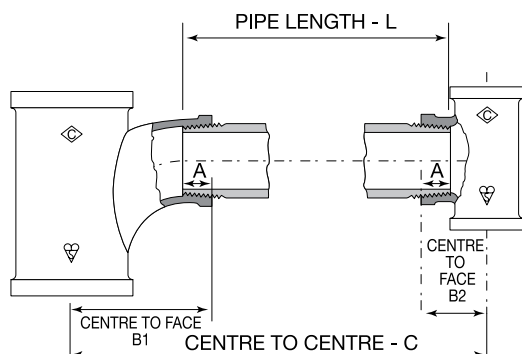

### 'A' Dimension Information

FITTING SIZE (inch)	A (mm)
1/8	7
1/4	10
3/8	10
1/2	13
3/4	15
1	17
1 1/4	19
1 1/2	19
2	24
2 1/2	27
3	30
4	36
5	40
6	40

### Pipe Ends

Users are advised to ensure that the external threads on the pipe being screwed into Crane fittings are free from damage or any malformation and conform to the gauging requirements of BS EN 10226.

### ISO - BS EN - BS Identification Symbols

SYMBOL	TYPE	CRANE FIG. NO. MALLEABLE
A1	Elbows	151
A1/45°		155
A4		152
B1	Tees	161
-		163
C1	Crosses	171
D1	Bends	193
D4		192
D4/45°		156
-		191
E1	Pitcher tees	199
E2	Twin elbows	197
-	Sockets	176
M2		177
M2		179
M3		180
N4	Bushes	140
N8	Nipples	144
N8		145
P4	Back nuts	150
T2	Caps	185
T8	Plugs	147
T8		148
T9		146
T11		149
U1	Unions	241
U11		256
U11		271
U11		289
U12		257
U12		272
UA11	Elbow	261
UA12		262

The symbols shown in the above table are those given in BS 143 & 1256, BS EN 10242 and ISO 49 for malleable iron fittings and in BS 143 & 1256 for copper alloy fittings, and relate to the identification of fitting types.

## Specification

### Designation of Fitting Size

The designation of fitting size for the fittings shown in this catalogue is as follows:

**EQUAL FITTINGS:** Equal fittings where all outlets are the same size are designated by that one size, irrespective of the number of outlets.

**UNEQUAL FITTINGS:** Unequal fittings (reducing or enlarging) are specified by the sizes of each outlet, the sequence being dependent on the number of outlets:

- (a) For fittings having two outlets, the larger outlet is specified first.

Example: Fig. No. 145 hexagon reducing nipple with one end threaded size 2 and other end threaded size 1, is designated 2 x 1.

- (b) For fittings having more than two outlets, Crane uses BS EN 10242 method (b) which gives the run as the first and second sizes of the designation and the branch as the third size of the designation.

This is in contrast to BS EN 10242 method (a) which gives the run as the first and third sizes of the designation and the branch as the second size of the designation. This method is used in certain international markets. (Please see the diagrams below for a visual explanation).

BS EN 10242 method (a) equivalents are specified in this catalogue where applicable.

UK method  
BS EN 10242 and ISO 49  
**Method (b) as used by Crane.**

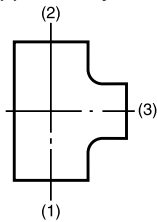

Fig. No. 161 tees

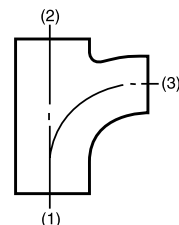

Fig. No. 199 pitcher tees

International method  
BS EN 10242 and ISO 49  
**Method (a)**

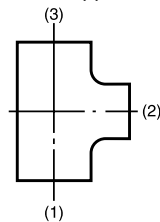

Fig. No. 161 tees

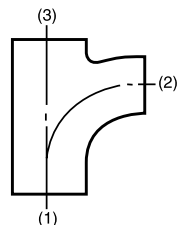

Fig. No. 199 pitcher tees

### Malleable Cast Iron

Crane malleable iron is of the Blackheart type ideally suited to pipe fitting and manufacture and conforms to BS EN 1562 Designation EN-GJMB-300-6, ASTM A197 and ISO 5922.

The close relationship between the physical properties of test bars and actual castings ensures design integrity and the preservation of high safety factors. Shock pressures within pipe systems can be tolerated with complete safety.

### Mild Steel

BS 143 and 1256 allow small size ( $3/8$ " and smaller) straight fittings to be supplied in other ferrous materials eg. mild steel, as an alternative to malleable cast iron, providing the mechanical properties are at least equivalent to the specified grade of malleable iron.

Individual data pages state which Crane fittings are supplied in mild steel.

### Galvanising

Where additional resistance to corrosion is required, malleable cast iron fittings can be hot-dip zinc coated (galvanised) prior to machining. This process involves coating the fittings with zinc which, in addition to its natural resistance to corrosion, provides electrochemical protection where the iron of the fitting is exposed by damage. Mild steel fittings can be supplied with a proprietary zinc-based coating.

The coating requirements on Crane galvanised fittings meet or exceed the requirements of BS EN 10242 with a minimum coating of 500g/m<sup>2</sup> corresponding to a thickness of 70µm.

When ordering galvanised or zinc coated fittings add the suffix 'G' to the figure number.

## Specification

### Pressure/Temperature Ratings

BS 143 & 1256 states that fittings are for general purposes for the transmission of fluids within the pressure and temperature ranges specified.

The graph below shows the BS pressure temperature ratings. Crane malleable iron fittings are suitable for use at these new ratings with the exception of certain unions (see note Ø below), but such use is dependent on the suitability of the connecting pipe material, the threaded joint and any thread sealants used. Due consideration should also be given to any applicable codes of practice. Pressures stated are maximum non-shock gauge.

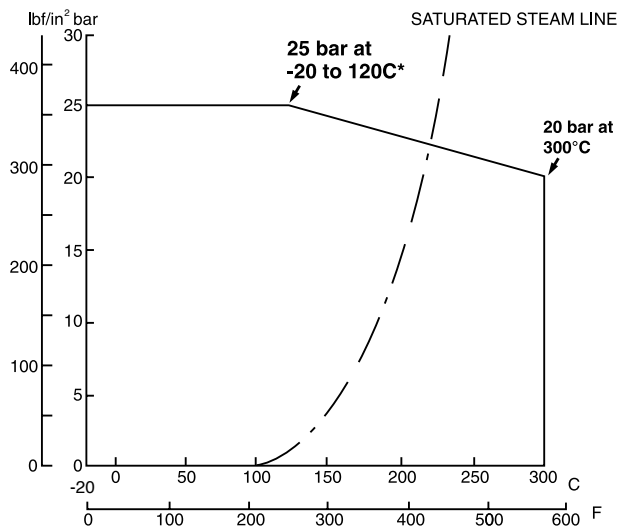

\*Hot dip zinc coated (galvanised) fittings should not be used below -10°C (14°F).

Figure No. 241 unions are limited to 230°C maximum.

Figure Nos. 271, 272 and 289 unions are limited to 208°C maximum.

Dimensions given do not allow for tapping or threading tolerances.

### Testing

Production testing: Meets requirements of BS EN 10242 or BS 143 and 1256 as applicable. Type testing: In addition to production testing, all pressure containing fittings are required by BS EN 10242, BS 143 & 1256 and ISO 49 to be designed to withstand specified design test pressures and to be type tested accordingly - 100 bar (1450 lbf/in<sup>2</sup>) for sizes 4 and smaller malleable iron fittings and 64 bar (928 lbf/in<sup>2</sup>) for sizes 5 and 6 malleable iron.

### Finish

All malleable iron fittings are given an oil finish as protection against rust while in stock or during transit and after installation prior to plant commissioning. Finished fittings are free of any polycyclic aromatic hydrocarbons.

### Marking

All Crane fittings are marked with the logo and where size permits, the fitting size and Kitemark symbol. In addition, some castings also display a pattern identification number. This is normally located next to the band of the fitting.

This number is used during the manufacturing process as part of the rigorous quality control procedures to ensure consistent high-quality castings. The number is not of relevance to the end user of the product.

# Malleable Iron



Options:



Galvanised

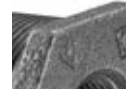

Black

## 140 Hexagon Bush PN25

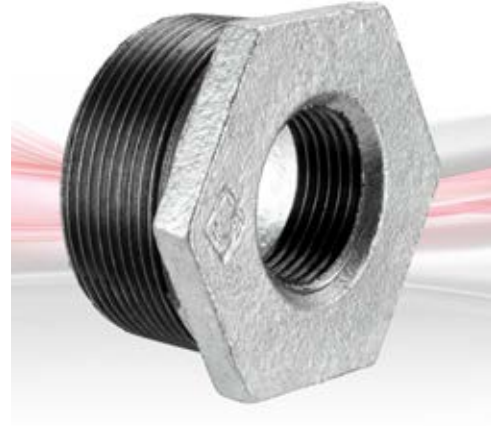
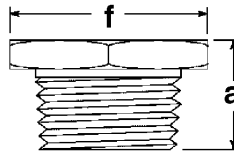

FITTING SIZE (inch)	DIMENSIONS (mm)		WEIGHT (kg) per 100 pieces
	a	f	
1/2 x 1/8 ✓	24	24	4.40
*1/2 x 1/4 ✓	24	24	3.74
1/2 x 3/8 ✓	24	24	3.20
3/4 x 1/8	26	30	7.70
3/4 x 1/4 ✓	26	30	7.07
3/4 x 3/8 ✓	26	30	6.50
3/4 x 1/2 ✓	26	30	5.30
1 x 1/4 ✓	29	36	11.80
1 x 3/8 ✓	29	36	12.18
1 x 1/2 ✓	29	36	10.60
1 x 3/4 ✓	29	36	8.20
1 1/4 x 1/2 ✓	31	46	20.24
1 1/4 x 3/4 ✓	31	46	17.70
1 1/4 x 1 ✓	31	46	14.00
1 1/2 x 1/2 ✓	31	52	25.40
1 1/2 x 3/4 ✓	31	52	24.20
1 1/2 x 1 ✓	31	52	21.00
1 1/2 x 1 1/4 ✓	31	52	14.30

FITTING SIZE (inch)	DIMENSIONS (mm)		WEIGHT (kg) per 100 pieces
	a	f	
2 x 1/2 ✓	35	64	36.90
2 x 3/4 ✓	35	64	37.40
2 x 1 ✓	35	64	40.30
2 x 1 1/4 ✓	35	64	35.40
2 x 1 1/2 ✓	35	64	29.98
2 1/2 x 1/2	40	79	62.36
2 1/2 x 1 ✓	40	79	61.40
2 1/2 x 1 1/4 ✓	40	79	63.00
2 1/2 x 1 1/2 ✓	40	79	66.29
2 1/2 x 2 ✓	40	79	49.50
3 x 1 ✓	44	93	87.10
3 x 1 1/4 ✓	44	93	87.60
3 x 1 1/2 ✓	44	93	92.49
3 x 2 ✓	44	93	92.30
3 x 2 1/2 ✓	44	93	63.00
4 x 1	51	118	149.30
4 x 1 1/2	51	118	148.40
4 x 2 ✓	51	118	158.43
4 x 2 1/2 ✓	51	118	161.72
4 x 3 ✓	51	118	144.25
5 x 4	58	144	208.20
6 x 4	61	171	352.80

✓ The following fitting is UL listed.

## Malleable Iron



LISTED



### 144 Octagon Nipple PN25

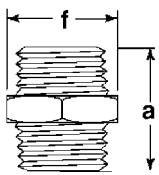

FITTING SIZE (inch)		DIMENSIONS (mm)		WEIGHT (kg) per 100 pieces
		a	f	
1/2	✓	44	23	6.50
3/4	✓	49	28	9.90
1		53	36	15.60
1 1/4		57	46	23.80
1 1/2		59	52	31.10
2		68	64	49.80
2 1/2		80	77	107.90
3		89	101	166.10
4		102	124	247.60

Options:



Galvanised



Black

### 145 Hexagon Nipple PN25

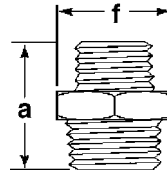

FITTING SIZE (inch)		DIMENSIONS (mm)		WEIGHT (kg) per 100 pieces
		a	f	
1/2 x 1/4	✓	41	23	6.20
1/2 x 3/8		41	23	6.50
3/4 x 3/8	✓	48	28	9.50
3/4 x 1/2	✓	49	28	9.80
1 x 1/2	✓	56	35	16.80
1 x 3/4	✓	56	35	15.43
1 1/4 x 1/2		64	44	25.03
1 1/4 x 3/4	✓	64	44	25.54
1 1/4 x 1	✓	64	44	21.50
1 1/2 x 1	✓	64	50	31.28
1 1/2 x 1 1/4	✓	64	50	28.12
2 x 1	✓	69	61	49.30
2 x 1 1/4	✓	69	61	45.50
2 x 1 1/2	✓	71	62	46.70
2 1/2 x 2	✓	77	77	72.00
3 x 2	✓	86	90	101.90
3 x 2 1/2	✓	85	90	100.10

## Malleable Iron



### 146 Beaded Plug - Solid PN25

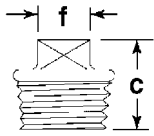

FITTING SIZE	DIMENSIONS (mm)		WEIGHT (kg) per 100 pieces
	c	f	
3/4 ✓	36	14	12.50
1 ✓	41	19	22.10
1 1/4 ✓	47	23	38.42
1 1/2 ✓	49	23	49.70
2 ✓	56	28	90.17

### 147 Plain Plug - Hollow PN25

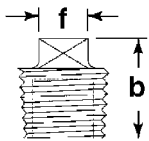

FITTING SIZE	DIMENSIONS (mm)		WEIGHT (kg) per 100 pieces
	b	f	
1/2 ✓	23	12	3.60
3/4 ✓	26	14	5.10
1 ✓	29	18	8.27
1 1/4 ✓	34	25	14.22
1 1/2 ✓	36	30	21.31
2 ✓	41	34	32.58
2 1/2 ✓	43	36	47.60
3 ✓	50	38	73.50
4 ✓	59	46	122.90

Options:



Galvanised



Black

### 148 Plain Plug - Solid PN25

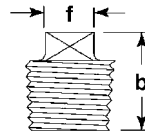

FITTING SIZE	DIMENSIONS (mm)		WEIGHT (kg) per 100 pieces
	b	f	
3/8 ✓	20	11	2.80
1/2 ✓	23	12	4.17
3/4 ✓	26	14	7.10
1 ✓	28	17	12.92
1 1/4 ✓	33	24	22.80
1 1/2 ✓	35	29	31.40
2 ✓	41	32	56.00

### 149 Countersunk Plug PN25

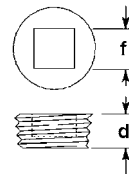

FITTING SIZE	DIMENSIONS (mm)		WEIGHT (kg) per 100 pieces
	d	f	
1/2 ✓	16	9	2.59
3/4 ✓	16	14	4.50
1 ✓	22	19	8.33
1 1/4	22	20	15.40
1 1/2	21	20	21.40
2	27	26	43.88

✓ The following fitting is UL listed.

## Malleable Iron



LISTED



### 150 Backnut PN25

Parallel thread to  
BS 2779 (ISO 228-1)

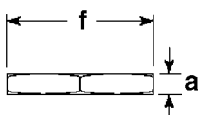
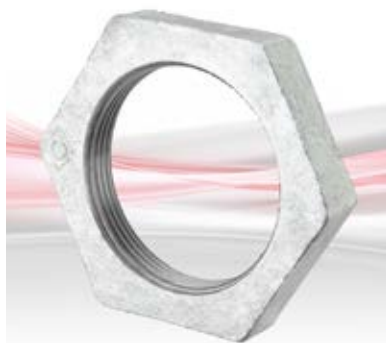

FITTING SIZE (inch)		DIMENSIONS (mm)		WEIGHT (kg) per 100 pieces
		a	f	
3/8	✓	8	26	1.90
1/2	✓	8	31	2.36
3/4	✓	9	38	4.19
1	✓	10	45	6.64
1 1/4	✓	11	55	10.05
1 1/2	✓	12	63	13.60
2	✓	13	76	23.40
2 1/2	✓	13	98	29.30
3		21	109	60.71

Options:



Galvanised



Black

### 151 Elbow PN25

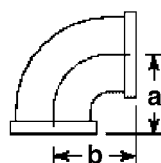

FITTING SIZE (inch)		DIMENSIONS (mm)		WEIGHT (kg) per 100 pieces
		a	b	
<b>Equal</b>				
1/8	✓	19	19	3.28
1/4	✓	21	21	5.10
3/8	✓	25	25	8.40
1/2	✓	28	28	8.40
3/4	✓	33	33	13.50
1	✓	38	38	22.40
1 1/4	✓	45	45	34.88
1 1/2	✓	50	50	44.10
2	✓	58	58	71.26
2 1/2	✓	69	69	138.40
3	✓	78	78	190.60
4	✓	96	96	353.20
5	✓	115	115	552.80
6	✓	131	131	764.00
<b>Reducing</b>				
1/2 x 1/4		25	25	8.00
1/2 x 3/8	✓	26	26	9.10
3/4 x 1/2	✓	30	31	13.20
1 x 1/2	✓	32	34	18.64
1 x 3/4	✓	35	36	22.00
1 1/4 x 1/2		36	41	26.80
1 1/4 x 3/4	✓	36	41	24.70
1 1/4 x 1	✓	42	46	32.00
1 1/2 x 3/4		39	44	32.00
1 1/2 x 1	✓	42	46	39.68
2 x 1		44	51	48.70
2 x 1 1/2	✓	52	55	69.90



# Malleable Iron



LISTED



## 152 Male & Female Elbow PN25

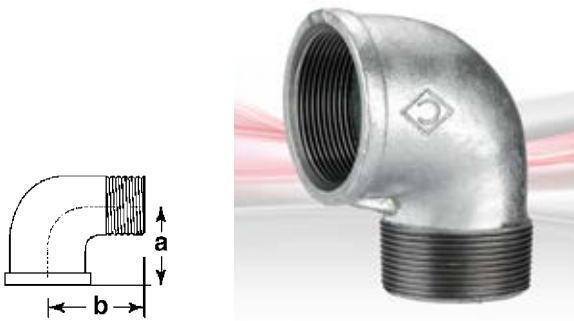

FITTING SIZE	DIMENSIONS (mm)		WEIGHT (kg) per 100 pieces
	a	b	
<b>Equal</b>			
1/8 ✓	19	25	2.60
1/4 ✓	21	28	4.03
3/8 ✓	25	32	6.10
1/2 ✓	28	37	8.99
3/4 ✓	33	43	13.37
1 ✓	38	52	23.00
1 1/4 ✓	45	60	35.10
1 1/2 ✓	50	68	48.42
2 ✓	58	74	78.08
2 1/2 ✓	69	88	115.60
3 ✓	78	98	164.70
4 ✓	96	118	293.00
<b>Reducing</b>			
3/4 x 1/2 ✓	30	40	10.50
1 x 3/4 ✓	35	46	21.40

Options:



Galvanised



Black

## 155 45° Elbow PN25

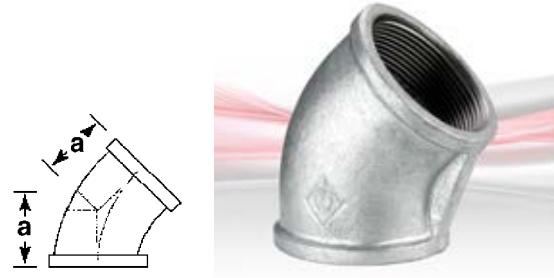

FITTING SIZE		DIMENSIONS (mm)		WEIGHT (kg) per 100 pieces
		a		
1/2 ✓		22		8.10
3/4 ✓		25		11.50
1 ✓		28		17.70
1 1/4 ✓		33		29.90
1 1/2 ✓		36		40.22
2 ✓		43		65.31
2 1/2		50		94.50
3		55		158.00
4		66		249.60
6		88		591.50

## 156 Elbow PN25



FITTING SIZE	DIMENSIONS (mm)		WEIGHT (kg) per 100 pieces
	a	f	
1/2 ✓	22	28	7.31
3/4 ✓	29	29	12.08
1 ✓	35	35	16.60
1 1/4 ✓	42	42	28.00
1 1/2 ✓	48	48	38.00
2 ✓	55	55	62.00
2 1/2	61	61	106.80
3	68	68	139.00
4	87	87	287.60

✓ The following fitting is UL listed.

# Malleable Iron



Options:

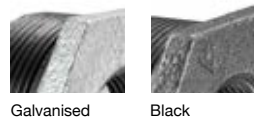

## 161 Tee PN25

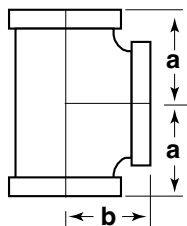

FITTING SIZE (inch) BS EN 10242		DIMENSIONS (mm)		WEIGHT (kg)
Method (b)	Method (a)	a	b	per 100 pieces
<b>Equal</b>				
1/8 ✓	-	19	19	3.95
1/4 ✓	-	21	21	6.20
3/8 ✓	-	25	25	8.89
1/2 ✓	-	28	28	11.63
3/4 ✓	-	33	33	18.86
1 ✓	-	38	38	29.34
1 1/4 ✓	-	45	45	45.00
1 1/2 ✓	-	50	50	69.07
2 ✓	-	58	58	93.95
2 1/2 ✓	-	69	69	189.40
3 ✓	-	78	78	271.90
4 ✓	-	96	96	469.30

FITTING SIZE (inch) BS EN 10242		DIMENSIONS (mm)		WEIGHT (kg)
Method (b)	Method (a)	a	b	per 100 pieces
1 1/4 x 1/2 ✓	-	34	38	30.14
1 1/4 x 3/4 ✓	-	36	41	43.20
1 1/4 x 1 ✓	-	40	42	42.16
1 1/2 x 1/2 ✓	-	36	42	45.40
1 1/2 x 3/4 ✓	-	38	44	42.60
1 1/2 x 1 ✓	-	42	46	50.72
1 1/2 x 1 1/4 ✓	-	46	48	61.50
2 x 1/2 ✓	-	38	48	56.06
2 x 3/4 ✓	-	40	50	70.40
2 x 1 ✓	-	44	52	68.27
2 x 1 1/4 ✓	-	48	54	73.70
2 x 1 1/2 ✓	-	52	55	93.50
2 1/2 x 1/2	-	41	57	103.80
2 1/2 x 3/4	-	44	59	109.90
2 1/2 x 1 ✓	-	47	60	120.80
2 1/2 x 1 1/4 ✓	-	52	62	130.80
2 1/2 x 1 1/2 ✓	-	55	63	139.80
2 1/2 x 2 ✓	-	61	66	154.60
3 x 1 ✓	-	-	-	143.10
3 x 1 1/4 ✓	-	55	70	169.70
3 x 1 1/2 ✓	-	58	71	177.60
3 x 2 ✓	-	64	73	190.70
3 x 2 1/2 ✓	-	72	76	228.60
4 x 1	-	56	81	
199.90				
4 x 1 1/4	-	61	83	273.90
4 x 1 1/2 ✓	-	64	84	279.20
4 x 2	-	70	86	242.80
4 x 2 1/2 ✓	-	77	89	365.70
4 x 3	-	84	92	302.50
6 x 4	-	105	125	745.20

FITTING SIZE (inch) BS EN 10242		DIMENSIONS (mm)		WEIGHT (kg)
Method (b)	Method (a)	a	b	per 100 pieces
<b>Reducing on branch</b>				
3/8 x 1/4 ✓	-	23	23	10.00
1/2 x 1/4 ✓	-	24	24	12.00
1/2 x 3/8 ✓	-	26	26	12.40
3/4 x 1/4 ✓	-	26	27	12.20
3/4 x 3/8 ✓	-	28	28	17.70
3/4 x 1/2 ✓	-	30	31	20.30
1 x 1/4 ✓	-	28	31	18.89
1 x 3/8 ✓	-	32	35	23.70
1 x 1/2 ✓	-	32	34	21.70
1 x 3/4 ✓	-	35	36	31.54

# Malleable Iron



## 161 Tee PN25

Options:

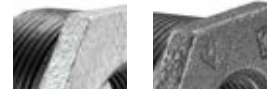

Galvanised

Black

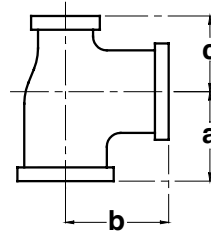

FITTING SIZE (inch) BS EN 10242		DIMENSIONS (mm)			WEIGHT (kg) per 100 pieces
Method (b)	Method (a)	a	b	c	
<b>Reducing on run</b>					
1/2 x 1/4 x 1/2	1/2 x 1/2 x 1/4	28	28	25	9.70
3/4 x 1/2 x 3/4 ✓	3/4 x 3/4 x 1/2	33	33	31	22.00
1 x 1/2 x 1 ✓	1 x 1 x 1/2	38	38	34	31.80
1 x 3/4 x 1 ✓	1 x 1 x 3/4	38	38	36	26.71
1 1/4 x 1/2 x 1 1/4 ✓	1 1/4 x 1 1/4 x 1/2	45	45	38	44.30
1 1/4 x 3/4 x 1 1/4 ✓	1 1/4 x 1 1/4 x 3/4	45	45	41	43.77
1 1/4 x 1 x 1 1/4 ✓	1 1/4 x 1 1/4 x 1	45	45	42	46.89
1 1/2 x 1/2 x 1 1/2 ✓	1 1/2 x 1 1/2 x 1/2	50	50	44	58.00
1 1/2 x 3/4 x 1 1/2 ✓	1 1/2 x 1 1/2 x 3/4	50	50	44	49.50
1 1/2 x 1 x 1 1/2 ✓	1 1/2 x 1 1/2 x 1	50	50	46	55.69
2 x 1/2 x 2 ✓	2 x 2 x 1/2	58	58	52	81.99
2 x 3/4 x 2 ✓	2 x 2 x 3/4	58	58	52	88.60
2 x 1 x 2 ✓	2 x 2 x 1	58	58	52	92.80
2 x 1 1/2 x 2	2 x 2 x 1 1/2				102.60
2 1/2 x 1 1/2 x 2 1/2	2 1/2 x 2 1/2 x 1 1/2	69	69	64	125.70
3 x 2 x 3	3 x 3 x 2	78	78	73	191.20
<b>Reducing on run &amp; branch</b>					
3/4 x 1/2 x 1/2 ✓	3/4 x 1/2 x 1/2	30	31	28	19.80
1 x 3/4 x 1/2 ✓	1 x 1/2 x 3/4	32	34	30	20.20
1 x 3/4 x 3/4 ✓	1 x 3/4 x 3/4	35	36	33	30.20

FITTING SIZE (inch) BS EN 10242		DIMENSIONS (mm)			WEIGHT (kg) per 100 pieces
Method (b)	Method (a)	a	b	c	
1 1/4 x 1 x 1 1/2 ✓	1 1/4 x 1/2 x 1	36	41	35	36.20
1 1/4 x 1 x 3/4 ✓	1 1/4 x 3/4 x 1	36	41	35	31.80
1 1/4 x 1 x 1 ✓	1 1/4 x 1 x 1	40	42	38	44.60
1 1/2 x 1 x 1 ✓	1 1/2 x 1 x 1	42	46	38	42.11
1 1/2 x 1 1/4 x 1/2 ✓	1 1/2 x 1/2 x 1 1/4	37	43	33	45.60
1 1/2 x 1 1/4 x 1 ✓	1 1/2 x 1 x 1 1/4	42	46	40	56.90
1 1/2 x 1 1/4 x 1 1/4 ✓	1 1/2 x 1 1/4 x 1 1/4	46	48	45	64.00
2 x 1 1/2 x 1 1/2 ✓	2 x 1/2 x 1 1/2	44	51	41	51.40
2 x 1 1/2 x 3/4 ✓	2 x 3/4 x 1 1/2	44	51	41	70.40
2 x 1 1/2 x 1 ✓	2 x 1 x 1 1/2	44	51	41	64.60
2 x 1 1/2 x 1 1/4 ✓	2 x 1 1/4 x 1 1/2	48	54	46	67.40
2 x 1 1/2 x 1 1/2	2 x 1 1/2 x 1 1/2	52	55	50	85.50

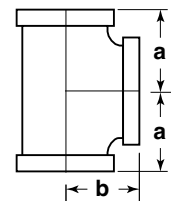

FITTING SIZE (inch) BS EN 10242		DIMENSIONS (mm)		WEIGHT (kg) per 100 pieces
Method (b)	Method (a)	a	b	
<b>Increasing on branch</b>				
1/2 x 3/4 ✓	-	31	30	18.24
3/4 x 1 ✓	-	36	35	26.10
1 x 1 1/4 ✓	-	42	40	43.60
1 x 1 1/2 ✓	-	46	42	42.75
1 1/4 x 2 ✓	-	54	48	75.10
1 1/2 x 2 ✓	-	55	52	89.80
2 x 2 1/2	-	66	61	120.50

## Malleable Iron



### 163 Male & Female Tee PN25

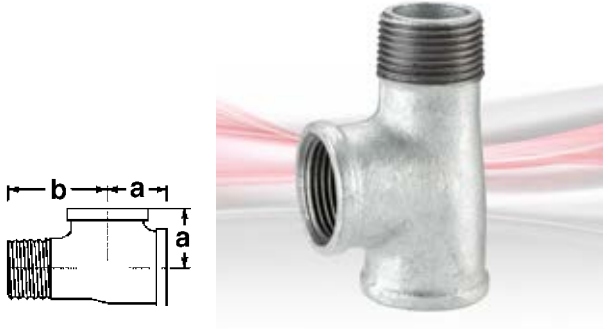

FITTING SIZE (inch)	DIMENSIONS (mm)		WEIGHT (kg) per 100 pieces
	a	b	
1/2	29	41	12.30
3/4	33	48	19.60
1	38	54	29.70

Options:



Galvanised



Black

### 171 Cross PN25

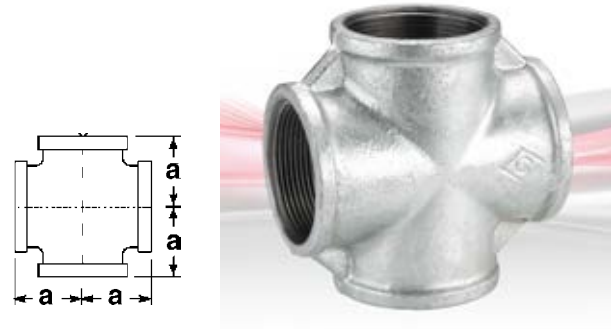

FITTING SIZE (inch)		DIMENSIONS (mm)		WEIGHT (kg) per 100 pieces
		a		
3/8	✓	25		9.75
1/2	✓	28		15.10
3/4	✓	33		22.20
1	✓	38		36.04
1 1/4	✓	45		73.60
1 1/2	✓	50		81.00
2	✓	58		119.10
2 1/2	✓	69		160.90
3	✓	78		232.50

## Malleable Iron



LISTED



### 176 Socket PN25



Parallel thread to  
BS 2779 (ISO 228-1)

FITTING SIZE (inch)	DIMENSIONS (mm) a	WEIGHT (kg) per 100 pieces
1/8	24	2.11
1/4	27	3.57
3/8	30	4.53
1/2	34	7.89
3/4	39	12.03
1	42	18.32
1 1/4	49	28.45
1 1/2	54	30.50
2	64	48.20
2 1/2	73	73.00
3	81	98.50
4	94	178.60

Options:



Galvanised



Black

### 177 Socket PN25

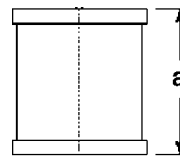

FITTING SIZE (inch)	DIMENSIONS (mm) a	WEIGHT (kg) per 100 pieces
1/4 ✓	27	3.20
3/8 ✓	30	4.00
1/2 ✓	34	8.32
3/4 ✓	39	12.30
1 ✓	42	19.95
1 1/4 ✓	50	22.10
1 1/2 ✓	55	31.10
2 ✓	65	50.20
2 1/2 ✓	73	94.80
3 ✓	81	128.25
4 ✓	94	215.00

## Malleable Iron



LISTED



Options:



Galvanised



Black

### 179 Reducing Socket PN25

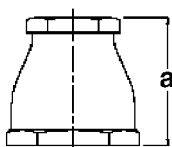

FITTING SIZE (inch)	DIMENSIONS (mm) a	WEIGHT (kg) per 100 pieces
1/2 x 1/4 ✓	32	7.60
1/2 x 3/8 ✓	32	8.40
3/4 x 1/4 ✓	37	12.70
3/4 x 3/8 ✓	37	7.62
3/4 x 1/2 ✓	37	14.35
1 x 1/2 ✓	45	14.75
1 x 3/4 ✓	43	19.80
1 1/4 x 1/2 ✓	52	24.91
1 1/4 x 3/4 ✓	52	26.97
1 1/4 x 1 ✓	50	20.60
1 1/2 x 1/2 ✓	59	33.85
1 1/2 x 3/4 ✓	59	33.60
1 1/2 x 1 ✓	59	37.76
1 1/2 x 1 1/4 ✓	55	27.30
2 x 1/2 ✓	71	48.40
2 x 3/4 ✓	71	48.90
2 x 1 ✓	71	54.10
2 x 1 1/4 ✓	65	43.10
2 x 1 1/2 ✓	71	57.81
2 1/2 x 1 ✓	83	77.50
2 1/2 x 1 1/4 ✓	83	78.60
2 1/2 x 1 1/2 ✓	83	83.58
2 1/2 x 2 ✓	83	88.68
3 x 2 ✓	94	110.10
3 x 2 1/2 ✓	94	108.60
4 x 2 ✓	111	194.40
4 x 2 1/2 ✓	111	196.30
4 x 3 ✓	111	202.70

### 180 Eccentric Socket PN25

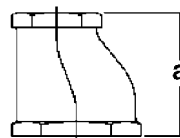

FITTING SIZE (inch)	DIMENSIONS (mm) a	WEIGHT (kg) per 100 pieces
3/4 x 1/2	37	12.92
1 x 1/2	43	17.33
1 x 3/4	43	18.92
1 1/4 x 1/2	52	19.34
1 1/4 x 3/4	52	25.39
1 1/4 x 1	52	25.28
1 1/2 x 1/2	59	34.60
1 1/2 x 3/4	59	28.82
1 1/2 x 1	59	37.08
1 1/2 x 1 1/4	59	46.67
2 x 1/2	71	57.01
2 x 3/4	71	57.85
2 x 1	71	56.42
2 x 1 1/4	71	54.91
2 x 1 1/2	71	53.30
2 1/2 x 1 1/2	83	96.66
2 1/2 x 2	83	139.90
3 x 2	94	115.70
3 x 2 1/2	94	197.00

# Malleable Iron



## 185 Cap PN25

Options:



Galvanised

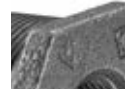

Black

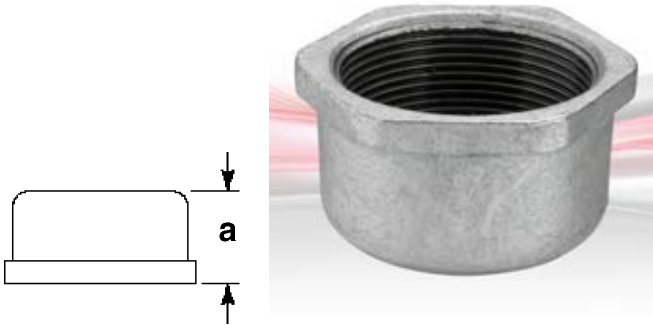

FITTING SIZE (inch)	DIMENSIONS (mm) a	WEIGHT (kg) per 100 pieces
1/2 ✓	26	7.50
3/4 ✓	27	7.39
1 ✓	32	15.10
1 1/4 ✓	32	20.20
1 1/2 ✓	33	26.00
2 ✓	38	43.29
2 1/2 ✓	41	66.18
3 ✓	44	92.20
4 ✓	52	177.46

## Malleable Iron



LISTED



Options:



Galvanised



Black

### 191 Male Bend PN25

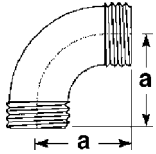

FITTING SIZE	DIMENSIONS (mm) a	WEIGHT (kg) per 100 pieces
1/2	45	10.21
3/4	50	13.20
1	63	23.13
1 1/4	76	41.50
1 1/2	85	57.68

### 193 Bend PN25

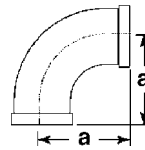

FITTING SIZE	DIMENSIONS (mm) a	WEIGHT (kg) per 100 pieces
1/2 ✓	45	13.42
3/4 ✓	50	19.15
1 ✓	63	31.82
1 1/4 ✓	76	61.70
1 1/2 ✓	85	79.26
2 ✓	102	126.57
2 1/2	114	166.70
3	127	252.50
4	165	485.30

### 192 Male & Female Bend PN25

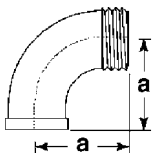

FITTING SIZE	DIMENSIONS (mm) a	WEIGHT (kg) per 100 pieces
1/2 ✓	45	10.10
3/4 ✓	50	16.00
1 ✓	63	26.70
1 1/4 ✓	76	50.50
1 1/2 ✓	85	69.61
2 ✓	102	108.60
2 1/2	114	158.80
3	127	239.60
4	165	467.50

### 197 Twin Elbow PN25

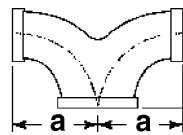

FITTING SIZE	DIMENSIONS (mm) a	WEIGHT (kg) per 100 pieces
1/2 ✓	45	19.00
3/4 ✓	50	29.40
1 ✓	63	48.30
1 1/4 ✓	76	87.34
1 1/2 ✓	85	117.29
2 ✓	102	172.50



# Malleable Iron



Options:



Galvanised



Black

## 199 Pitcher Tee PN25

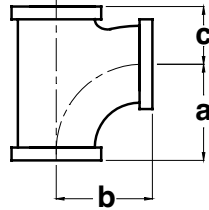

FITTING SIZE (inch) BS EN 10242		DIMENSIONS (mm)			WEIGHT (kg)
Method (b)	Method (a)	a	b	c	per 100 pieces
<b>Equal</b>					
1/2	✓	45	45	24	20.24
3/4	✓	50	50	28	26.00
1	✓	63	63	33	40.80
1 1/4	✓	76	76	40	73.55
1 1/2	✓	85	85	43	101.17
2	✓	102	102	53	145.70
2 1/2		114	114	61	255.00
3		127	127	70	352.10
4		165	165	87	591.00
<b>Reducing on branch</b>					
3/4 x 1/2	✓	47	48	25	22.53
1 x 1/2	✓	49	51	28	32.77
1 x 3/4	✓	53	56	30	34.26
1 1/4 x 1/2	✓	51	56	30	43.69
1 1/4 x 3/4	✓	55	58	33	48.80
1 1/4 x 1	✓	66	68	36	60.70
1 1/2 x 1/2		52	58	29	51.50
1 1/2 x 3/4	✓	55	61	33	56.50
1 1/2 x 1	✓	66	71	36	72.34
1 1/2 x 1 1/4	✓	77	79	41	90.01
2 x 1/2		54	64	32	75.93
2 x 3/4		58	67	35	82.75
2 x 1	✓	70	77	40	96.30
2 x 1 1/4	✓	80	85	45	111.70
2 x 1 1/2	✓	91	94	48	138.28

FITTING SIZE (inch) BS EN 10242		DIMENSIONS (mm)			WEIGHT (kg)
Method (b)	Method (a)	a	b	c	per 100 pieces
2 1/2 x 1		72	85	40	129.20
2 1/2 x 1 1/4		83	93	45	145.10
2 1/2 x 1 1/2		94	103	48	175.30
2 1/2 x 2		104	109	54	221.80
3 x 1 1/2		96	109	50	231.80
3 x 2		106	116	56	261.20
4 x 2 1/2		121	133	69	454.70
<b>Reducing on run &amp; branch</b>					
3/4 x 1/2 x 1/2	✓	47	48	24	20.20
1 x 3/4 x 1/2	✓	49	51	25	26.00
1 x 3/4 x 3/4	✓	53	54	28	30.10
<b>Reducing on run</b>					
3/4 x 1/2 x 3/4	✓	50	50	27	24.30

## Malleable Iron



Options:



Galvanised



Black

### 241 Union PN25

FLAT SEAT

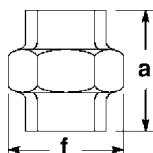

FITTING SIZE	DIMENSIONS (mm)		WEIGHT (kg) per 100 pieces
	a	f	
1/2	49	42	20.44
3/4	53	49	30.39
1	58	57	41.22

### 299 Gasket for Fig. 241

FITTING SIZE	WEIGHT (kg) per 100 pieces
1/2	-
3/4	-
1	-

(compressed non-asbestos fibre)

### 256 Union PN25

SPHERICAL SEAT - Iron to Iron

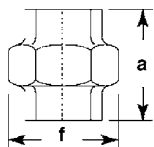

FITTING SIZE	DIMENSIONS (mm)		WEIGHT (kg) per 100 pieces
	a	f	
1/4	42	32	11.14
3/8	45	36	13.75
1/2	49	42	20.70
3/4	53	49	30.08
1	58	57	40.75
1 1/4	64	68	60.67
1 1/2	68	76	78.49
2	75	92	119.89
2 1/2	84	111	187.05
3	92	125	248.33
4	107	155	426.52

### 257 Male & Female Union PN25

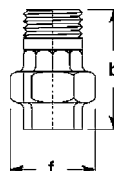

FITTING SIZE	DIMENSIONS (mm)			WEIGHT (kg) per 100 pieces
	b	a	f	
1/4	57	32	†	11.95
3/8	61	36	†	16.07
1/2	68	56	42	25.85
3/4	74	74	49	36.77
1	82	57	57	50.63
1 1/4	91	68	†	74.26
1 1/2	95	76	†	99.95
2	104	92	†	147.70
2 1/2	116	111	†	232.78
3	131	125	†	324.66

### 261 Elbow Union PN25

SPHERICAL SEAT - Iron to Iron

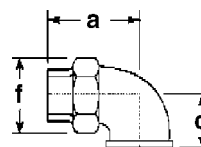

FITTING SIZE	DIMENSIONS (mm)			WEIGHT (kg) per 100 pieces
	a	c	f	
1/2	56	28	42	25.72
3/4	64	33	49	37.31
1	72	38	57	54.38

## Malleable Iron



Options:



Galvanised



Black

### 262 M & F Elbow Union PN25

SPHER-  
ICAL SEAT -  
Iron to Iron

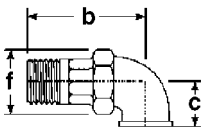

FITTING SIZE	DIMENSIONS (mm)			WEIGHT (kg) per 100 pieces
	b	c	f	
1/2	78	28	42	29.89
3/4	86	33	49	44.44
1	98	38	57	62.88

### 271 Union PN25

SPHER-  
ICAL SEAT -  
Bronze to Iron

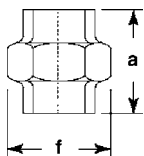

FITTING SIZE	DIMENSIONS (mm)		WEIGHT (kg) per 100 pieces
	a	f	
1/8	42	32	12.26
1/4	42	32	11.03
3/8	45	36	14.54
1/2	49	42	20.69
3/4	53	49	30.33
1	58	57	40.79
1 1/4	64	68	59.64
1 1/2	68	76	77.87
2	75	92	120.10
2 1/2	84	111	187.15
3	92	125	247.81
4	107	155	432.60

## Malleable Iron



Options:

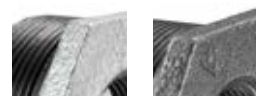

Galvanised

Black

### 289 Union PN25

SPHER-  
ICAL SEAT -  
Bronze to Bronze

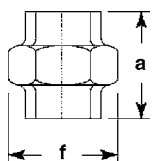

FITTING SIZE	DIMENSIONS (mm)		WEIGHT (kg) per 100 pieces
	a	f	
1/4	42	32	10.91
3/8	45	36	14.98
1/2	49	42	20.97
3/4	53	49	30.44
1	58	57	40.99
1 1/4	64	68	61.13
1 1/2	68	76	79.78
2	75	92	121.54
2 1/2	84	111	187.72
3	92	125	248.02

### 290 Union PN25

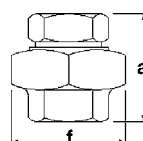

FITTING SIZE	DIMENSIONS (mm)		WEIGHT (kg) per 100 pieces
	a	f	
1/2	49	44	22.96
3/4	52	48	28.66
1	57	55	37.44
1 1/4	67	67	60.00
1 1/2	78	76	94.48
2	87	90	134.79

### The Crane SA (Self Aligning Union)

The Crane SA Union is made with double spherical seats. Pipes which are not in alignment can be securely connected at any angle up to 6° of arc from centre line of the union, thus avoiding the need for offsets. The union provides a pressure tight joint without the use of gaskets or washers.

- Self aligning (SA) Union
- Double spherical seats
- Iron to iron seating
- Taper threads to BS EN 10226
- Black or Galvanised



SA Union - female



6° out of alignment and still pressure tight



